

MAHLE ACX2120H

EN

Operation manual
A/C Service Equipment



Contents

| | | | |
|---|-----------|--|-----------|
| 1. Symbols use | 4 | 6. Commissioning | 14 |
| 1.1 In the documentation | 4 | 6.1 Connections and positioning | 14 |
| 1.1.1 Warning notices—Structure and meaning | 4 | 6.2 First start-up verification | 14 |
| 1.1.2 Symbols in this documentation | 4 | | |
| 1.2 On the product | 4 | 7. Setup | 15 |
| | | 7.1 ACX2120H | 15 |
| 2. Important notes | 4 | 7.1.1 EcoLOCK | 15 |
| 2.1 User group | 4 | 7.1.2 Recharge mode | 15 |
| 2.2 Agreement | 4 | 7.1.3 Pressure check | 15 |
| 2.3 Obligation of contractor | 5 | 7.1.4 Multipass | 15 |
| 2.4 Safety regulations | 6 | 7.1.5 Report saving mode | 15 |
| 2.4.1 ACX2120H | 6 | 7.1.6 Unit of measure | 15 |
| 2.5 Safety devices | 7 | 7.1.7 Clock adjustment | 16 |
| | | 7.1.8 Setting language | 16 |
| | | 7.1.9 Startup screen | 16 |
| | | 7.1.10 Default setup | 16 |
| 3. Product description | 8 | | |
| 3.1 Application | 8 | 8. A/C sevice preparation | 17 |
| 3.2 Scope of delivery | 8 | 8.1 Preliminary operations | 17 |
| 3.3 Description of unit | 9 | 8.2 Non-condensable gas discharge | 17 |
| 3.4 User interface | 10 | 8.3 Charge modes | 17 |
| 3.4.1 Selection and function keys | 10 | 8.3.1 Quick mode | 17 |
| 3.4.2 Input keys | 10 | 8.3.2 Zero tolerance mode | 17 |
| 3.4.3 Display screen | 11 | | |
| 3.4.4 Main menu options | 11 | 9. A/C system service | 18 |
| 3.5 Unit features | 11 | 9.1 Automatic cycles | 18 |
| 3.5.1 EcoLOCK® quick couplers | 11 | 9.2 Manual cycles | 19 |
| 3.5.2 Locking caster brakes | 11 | 9.2.1 Recovery process | 19 |
| 3.5.3 Power supply cable and switch | 11 | 9.2.2 Vacuum process | 19 |
| 3.6 Functional description | 12 | 9.2.3 Recharge | 20 |
| | | 9.2.4 Flushing (with optional accessories) | 20 |
| 4. Technical features | 12 | 9.2.5 Pressure check | 20 |
| | | 9.2.6 Hose emptying | 20 |
| 5. Equipment installation | 13 | | |
| 5.1 Unpacking ACX2120H | 13 | | |
| 5.2 Load cell screw release | 13 | | |

| | |
|--|-----------|
| 10. Maintenance | 21 |
| 10.1 Maintenance interval | 21 |
| 10.2 Filling internal refrigerant cylinder | 21 |
| 10.3 Self leak test | 22 |
| 10.4 Cylinder pressure check | 22 |
| 10.5 Cylinder refrigerant view | 22 |
| 10.6 Pressure zero | 22 |
| 10.7 Counters | 22 |
| 10.8 Long life pump test | 23 |
| 10.9 Vacuum pump oil change | 23 |
| 10.10 Replace filter dryer | 24 |
| 10.11 Multipass | 24 |
| 10.12 System info | 24 |
| 10.13 Software update | 25 |
| 10.14 Refrigerant weight accuracy check | 25 |
| 10.15 Printer maintenance | 26 |
| 10.16 Periodic checks | 26 |
| 11. Spare parts | 27 |
| 12. Disposal | 27 |
| 12.1 A/C Service unit disposal | 27 |
| 12.2 Recycled material disposal | 27 |
| 12.3 Packaging disposal | 27 |
| 13. Troubleshooting | 28 |
| 13.1 ACX2120H | 28 |
| 14. Maintenance forms | 30 |
| 14.1 Vacuum pump oil change | 30 |
| 14.2 Filter dryer change | 32 |
| 14.3 Refrigerant load cell calibration check | 35 |
| 14.4 Other checks/maintenance/repairs | 37 |
| 15. Notes | 39 |

1. Symbols use

1.1 In the documentation

1.1.1 Warning notices - Structure and meaning

Warning notices warn of dangers to the user or people in the vicinity. Warning notices also indicate the consequences of the hazard as well as preventive action. Warning notices have the following structure:

| | |
|----------------|---|
| Warning symbol | KEYWORD - Nature and source of hazard! Consequences of hazard in the event of failure to observe action and information given. ▶ Hazard prevention action and information. |
|----------------|---|

The key word indicates the likelihood of occurrence and the severity of the hazard in the event of non-observance:

| Key word | Probability of occurrence | Severity of danger if instructions not observed |
|----------------|-------------------------------------|---|
| DANGER | Immediate danger impending | Death or severe injury |
| WARNING | Possible danger impending | Death or severe injury |
| CAUTION | Possible dangerous situation | Minor injury |

1.1.2 Symbols in this documentation

| Symbol | Designation | Explanation |
|----------|----------------------|---|
| ⚠ | Attention | Warns about possible property damage. |
| i | Information | Practical hints and other useful information. |
| 1. 2. | Multi-step operation | Instruction consisting of several steps. |
| ▶ | One-step operation | Instruction consisting of one step. |
| ⇨ | Intermediate result | An instruction produces a visible intermediate result. |
| ➔ | Final result | There is a visible final result on completion of the instruction. |

1.2 On the product

⚠ Observe all warning notices on products and ensure they remain legible.



▶ Wear protective goggles.



▶ Wear protective gloves.

2. Important notes



Before start up, connecting and operating MAHLE products it is absolutely essential that the Original instructions/owner's manual and, in particular, the safety instructions are studied carefully. By doing so you can eliminate any uncertainties in handling MAHLE products and thus associated safety risks upfront; something which is in the interests of your own safety and will ultimately help avoid damage to the device. When a MAHLE product is handed over to another person, not only the Original instructions but also the safety instructions and information on its designated use must be handed over to the person.

2.1 User group

The product may be used by skilled and instructed personnel only. Personnel scheduled to be trained, familiarized, instructed or to take part in a general training course may only work with the product under the supervision of an experienced person. All work conducted on pressurized equipment may be performed by persons with sufficient knowledge and experience in the field of refrigeration, cooling systems and coolants and, also be aware of the risks involved in the use of pressurized devices.

2.2 Agreement

By using the product you agree to the following regulations:

Copyright

Software and data are the property of MAHLE or its suppliers and protected against copying by copyright laws, international agreements and other national legal regulations. Copying or selling of data and software or any part thereof is impermissible and punishable; in the event of any infringements MAHLE reserves the right to proceed with criminal prosecution and to claim for damages.

Liability

All data in this program is based—where possible—on manufacturer and importer details. MAHLE does not accept liability for the correctness and completeness of software and data; liability for damage caused by faulty software and data is ruled out. Whatever the event, MAHLE liability is restricted to the amount for which the customer actually pays for this product. This disclaimer of liability does not apply to damages caused by intent or gross negligence on the part of MAHLE.

Warranty

Any use of non-approved hardware and software will result in a modification to our product and thus to exclusion of any liability and warranty, even if the hardware or software has in the mean time been removed or deleted.

No changes may be made to our products. Our products may only be used in combination with original accessories and original service parts. Failing to do so, will render null and void all warranty claims.

This product may only be operated using MAHLE approved operating systems. If the product is operated using an operating system other than the approved one, then our warranty obligation pursuant to our supply conditions will be rendered null and void. Furthermore, we will not be held liable for damage and consequential damage incurred through the use of a non-approved operating system.

2.3 Obligation of contractor

The contractor is obliged to ensure that all measures geared towards the prevention of accidents, industrial diseases, labor-related health risks are taken and measures towards making the workplace fit for people to work in are carried out.

Specifications for electrical systems (BGV A3)

Electrical engineering in Germany is subject to the accident prevention regulations of the trade association "Electrical Plant and Equipment as under BGV A3 (previously VBG 4)". In all other countries, the applicable national regulations acts or decrees are to be adhered to.

Basic rules

The contractor is bound to ensure that all electrical equipment and operating material is set up, modified and maintained by skilled electricians only or under the guidance and supervision of a skilled electrician in accordance with electrical engineering principles.

Furthermore, the contractor must ensure that all electrical equipment and operating material is operated in keeping with electrical engineering principles.

If a piece of electrical equipment or operating material is found to be defective, i.e. it does not or no longer complies with electrical engineering principles, the contractor must ensure that the fault is rectified immediately and, in the event that imminent danger exists, also ensure that the electrical equipment or the electrical operating material is not used.

Tests (taking Germany as an example)

- The contractor must ensure that all electrical systems and equipment are tested by a qualified electrician or under the guidance of a qualified electrician to ensure they are in proper working order:
 - Before starting for the first time.
 - After modification or repair before starting for the first time.
 - At given intervals. Set intervals such as to ensure that faults that can be expected to occur are determined in good time.
- The test is to take the electrical engineering principles relating hereto into account.
- Upon request of the trade association, a test manual is to be maintained into which specific entries are made.

2.4 Safety regulations

2.4.1 ACX2120H

Always carefully study and follow all the safety regulations before using the MAHLE product.



Avoid all skin contact with the refrigerant. The low boiling point of the refrigerant (approx. $-30\text{ }^{\circ}\text{C}$) can lead to frostbite. Should refrigerant come into contact with the skin, remove any moistened clothing immediately and rinse the area of skin affected with generous amounts of water.

- Avoid all skin contact with the UV dye. Should UV dye come into contact with the skin, remove any moistened clothing immediately and rinse the area of skin affected with generous amounts of water.
- R134a is colorless, with weak characteristic smell and heavier than air. It may flow into repair pits. Should refrigerant escape, provide for sufficient ventilation (particularly in repair pits) and leave the workshop.



Never inhale refrigerant, dye and oil vapors. The vapors can irritate the eyes, nose and respiratory system. If liquid refrigerant or UV dye comes into contact with the eyes, rinse them thoroughly with water for 15 minutes. Then obtain medical attention even if no pain is felt.

- Never swallow UV dye. Should it be swallowed inadvertently, never attempt to induce vomiting. Drink generous amounts of water and obtain medical attention.
- Before connecting the ACX2120H to a vehicle air conditioning system or an external refrigerant bottle, make sure the quick-release couplings are not leaking. Only ever use external refrigerant bottles provided with safety valves and certified inline with the applicable standards.
- Before switching off the ACX2120H, make sure all charging and drainage operations have been completed. This prevents damage to the unit and reduces risk of refrigerant escaping into the environment.



Never use compressed air with R134a. Certain mixtures of air and R134a are highly flammable. Such mixtures are a potential hazard and may lead to fire or explosions and thus cause damage or injury.

- Refrigerant extracted from a vehicle air conditioning system may be contaminated with moisture, lubricant, dirt and traces of other gases.
- If the refrigerant has been contaminated by being mixed with other gases, remove the contaminated refrigerant and add fresh R134a before using the ACX2120H for A/C service.
- R134a is not to be used in areas in which there is a danger of explosion. Fire, open flames and smoking are prohibited. Welding and soldering are not permitted.
- The ACX2120H unit should not be exposed to excess moisture or be operated in wet areas.
- R134a is not to be mixed with other refrigerants. The mixing of refrigerants could damage the vehicle air conditioning system.



If high-voltage components or high-voltage wires are handled incorrectly, there is a risk of fatal injury from high voltage and the possible transmission of current through the body.

- De-energizing is only to be performed by a qualified electrician, a qualified electrician for specific tasks (hybrid) or a power systems engineer.
- Work on vehicles with high-voltage components is only ever to be performed in a safe, de-energized condition by persons with the minimum qualification "Trained to perform electrical work".
- Even after deactivating a high-voltage vehicle electrical system, the high-voltage battery may still be live.
- Operating condition cannot be established from any running noise, as the electric machine is silent when stationary.
- In gear positions "P" and "N" the engine or electric motor may start spontaneously depending on the charge of the high-voltage battery.
- Never open or damage high-voltage batteries.
- On vehicles that have been in an accident, never touch high-voltage components or exposed high-voltage wires before deactivating the high-voltage vehicle electrical system.
- The ACX2120H must be constantly monitored when in operation. Never leave the ACX2120H unattended when in operation.
- Vehicle A/C service using the ACX2120H must be prepared and implemented such that the vehicle air conditioning system circuit does not have to be opened (for example by removing the radiator or engine).
- Position the ACX2120H on all four wheels on a flat, vibration-proof surface so that proper operation of the scales is guaranteed.
- The ACX2120H can be secured in position by locking the caster brake.

- The ACX2120H must always be transported in its operating position. Never lay the ACX2120H on its side, as oil could then escape from the vacuum pump or the built in compressor could be damaged.
- There are no additional safety systems for protecting the ACX2120H against damage resulting from natural catastrophes.
- Never remove any components from inside the ACX2120H except for maintenance or repair purposes.
- Follow the pertinent legal regulations or directives to ensure safe handling of pressurized devices.
- We recommend calibrating the scales at least once per year. Contact customer service for calibration of the scales.
- The ACX2120H must be subjected to regular maintenance by service personnel or authorized agents to ensure the safety of the unit.
- Disconnect power before performing any maintenance or service to unit.
- Never perform any maintenance work which is not expressly recommended in this manual. Contact customer service if components have to be replaced other than in the course of maintenance work.
- ACX2120H must be connected to a properly grounded electrical connection.
- If there is damage to the ACX2120H, terminate usage immediately and contact customer service.
- The service hoses and service quick-release couplings must be regularly checked for wear and replaced if damaged.
- The ACX2120H must be operated in an environment corresponding to the directive BGR 157 with respect to the exchange of air.
- Observe local laws or directives as to ensure the safety of the pressurized device.

- For safety reasons it is advisable to use a residual current operated circuit breaker (rccb) with the following specifications:

| Parameters | Specification |
|------------------------|-------------------|
| Rated voltage | 110 VAC \pm 10% |
| Rated frequency | 50/60Hz |
| Rated current | 10A |
| Rated tripping current | 30mA |
| Tripping switch | C |

2.5 Safety devices

| Description | Function |
|-----------------|--|
| Pressure switch | Switches the compressor off if the normal operating pressure is exceeded. |
| Safety valve | The safety valve opens if the design pressure is exceeded. |
| Circuit breaker | Interrupts the power supply if overcurrent is applied to the ACX2120H . |
| Vents | The ACX2120H is provided with vents in the bottom of the housing to ensure the exchange of air even when switched off. |

3. Product description

3.1 Application

ACX2120H is suitable for vehicles with a conventional engine as well as for hybrid and electric vehicles. ACX2120H features all the functions required for vehicle A/C service.

The following functions can be implemented:

- Refrigerant recovery and recharging.
- Vacuum generation.
- Flushing.

⚠ The ACX2120H can only be operated with R134a. The ACX2120H is not to be used for service work on vehicles with air conditioning systems employing refrigerants other than R134a, as this will cause damage. Prior to A/C service check the type of refrigerant used in the vehicle air conditioning system.

3.2 Scope of delivery

| Description |
|---|
| Service hose (high pressure) |
| Service hose (low pressure) |
| Quick-release coupling (high pressure) |
| Quick-release coupling (low pressure) |
| Used oil bottle |
| Original instructions |
| Adapter (external bottle) - US Acme 1/2 |
| Calibration check weight |

3.3 Description of unit



Fig. 1: Front Left View

1. Rear Handle
2. Tool Tray
3. LCD Display
4. Keypad
5. Low Pressure Gauge
6. High Pressure Gauge
7. Front Cover
8. Locking Caster
9. Rear Wheel
10. Used Oil Bottle
11. Printer (optional)

SEE FIGURE A
(SEE BELOW)

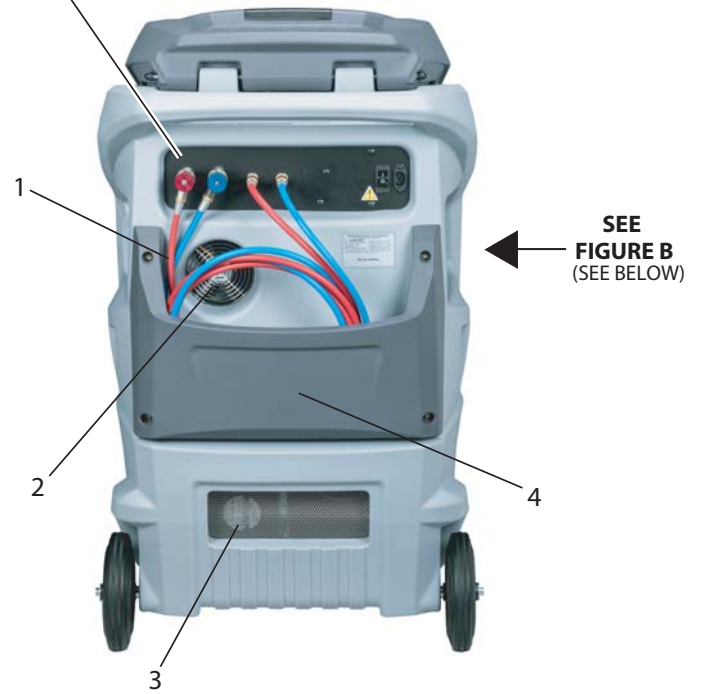

Fig. 2: Rear View

1. Service Hoses
2. Fan
3. Vent
4. Hose Storage

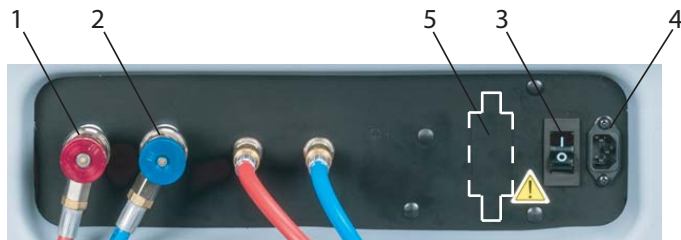

Fig. A: Rear Connection View

1. High Side Parking Coupler
2. Low Side Parking Coupler
3. Power Switch with circuit breaker
4. Power Cord Connector
5. Identifier (optional)

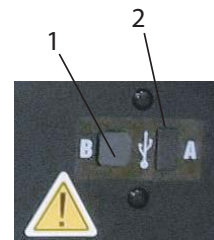

Fig. B: USB Ports

1. USB Type B (device port to PC)
2. USB Type A (USB memory stick port)

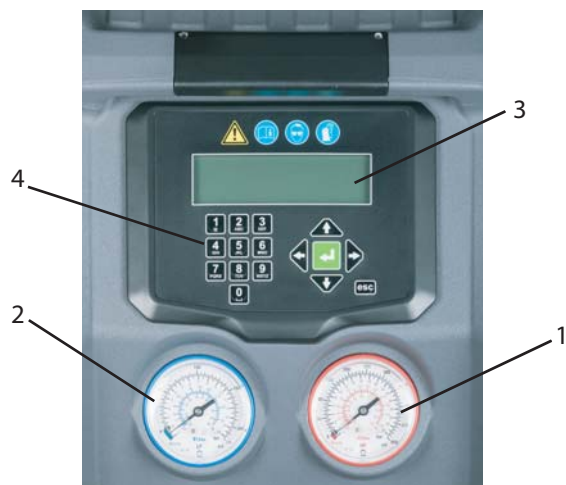

Fig. 4: Display and operating unit

- 1 High-pressure gauge
- 2 Low-pressure gauge
- 3 LCD display
- 4 Keypad

The pressure gauges (Fig. 4, Pos. 1, 2) of the display and operating unit are used to monitor the pressure during the individual vehicle A/C service phases. The status of the various service phases during maintenance is displayed on the LCD screen (Fig. 4, Pos. 3).

The menu selection and necessary entries are made by way of the keypad (Fig. 4, Pos. 4) integrated in the panel.

If a situation arises where the unit software requires updated, MAHLE has a USB stick available for updating the ACX2120H software. The USB stick can be inserted in the USB socket to perform updating of the firmware/software.

3.4 User interface

3.4.1 Selection and function keys

All settings, controls and service functions are available in the pages shown on the LCD display. Data entry and moving of the cursor is controlled by the keypad. The LCD displays the service equipment's status, the progress of A/C system service and any alarms/error messages. When a button is pressed, a beep sounds.

The following buttons are available:



Fig. 5: ACX2120H keypad

| Keys | Name | Function |
|------|-----------------------|---|
| | Up | To move up in the menu options or data field |
| | Down | To move down in the menu options or data field |
| | Left | Arrow to decrease data value |
| | Right | Arrow to increase data value |
| | Keypad/ Input Keys | To enter a text with numbers and/or characters. To enter letters/symbols, push key multiple times to select one of the letters available under that key - just as the keyboard of a phone to compose SMS. |
| | Enter | To confirm and go ahead |
| | Escape | To interrupt the operation in progress |

3.4.2 Input keys

The input keys can be used to enter letters, numbers and special characters in the input boxes. If a key is pressed several times in succession in the input box, all the characters which can be used for this are displayed.

3.4.3 Display screen

When unit loads, the total refrigerant weight screen will be displayed. Press \leftarrow to go to main menu as displayed in Fig. 6. To select a function in the menu, press the \uparrow or \downarrow to scroll to name of the desired function. The text name will blink once highlighted, then press the green ENTER key to select.

The menu moves up/down one line for every push of the \uparrow or \downarrow key.

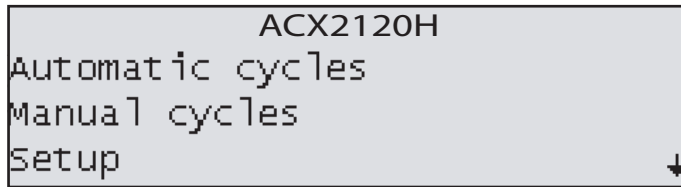

Fig. 6: Main menu screen

If you need to enter free text, the numerical keypad can be used. The keyboard works like a keyboard of a phone to compose SMS: press some times to select one of the letters available under that key.

3.4.4 Main menu options

The main menu of the graphical user interface allows user to select the following functions:

- Automatic cycles
- Manual cycles
- Setup
- Maintenance
- Service

Each of the menu options will be described in detail later in the manual.

3.5 Unit features

3.5.1 EcoLOCK® quick couplers (optional)

EcoLOCK® is the intelligent coupler, that with the suitable automated procedure in the software enables to:

- reduce the amount of non-condensable gases formed inside the cylinder,
- avoid the refrigerant (loss) dispersion in the air during the disconnection of the couplers (puff-effect),
- check possible Schrader valve leaks before disconnection.



Fig. 7: EcoLOCK® couplers

To connect the coupling, position the coupling on the parking coupler, pull back the knurled section of the coupling element and press carefully onto the connection (Fig. 8).

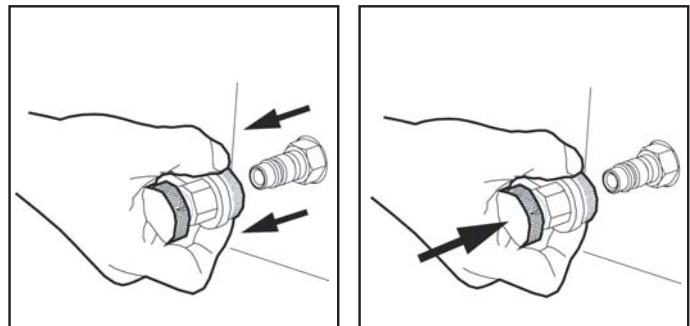

Fig. 8: Fastening quick release coupling

- ❗ The service quick-release couplings are connected to the service connections of the vehicle air conditioning system during A/C service. When not in use, the service quick-release couplings can be connected to the parking/flush couplers.
- ❗ To remove the service quick-release couplings from the parking/flush coupler, press the coupling slightly towards the connection and carefully pull the knurled section back to unfasten it from the coupler.

3.5.2 Locking caster brakes

Rolling of the ACX2120H can be prevented by locking the caster brakes (Fig. 1, Pos. 8) at the front wheels.

3.5.3 Power supply cable and switch

The power supply cable is connected to the main power input. When not in operation, the power supply cable can be disconnected and hung on the handle. The ACX2120H is switched on by toggling the rocker switch to the on position.

3.6 Functional description

The refrigerant recovered from the air conditioning system passes through the combo filter to remove suspended particles and moisture.

The purpose of the vacuum pump is to generate a vacuum in the air conditioning system which removes excess moisture and to detect possible leaks in the vehicle air conditioning system.

Used oil is separated from the recovered vehicle refrigerant and drained into the used oil bottle.

The vehicle air conditioning system is partly filled with UV dye to facilitate the detection of leaks in the event of damage to the vehicle air conditioning system.

The refrigerant in the internal refrigerant bottle is used for filling the vehicle air conditioning system.

The purging unit for the non-condensable gases, consisting of a temperature sensor, pressure sensor, coil and orifice, always takes effect when the internal refrigerant bottle pressure is higher than the saturation pressure.

4. Technical features

| Description | Specification |
|-----------------------------------|--|
| R134a tank capacity | 12L |
| Service pressure | 400PSI |
| Maximum content | 22lbs |
| Method to weigh gas content | Load cell |
| Recovered oil container | 250ml |
| Vacuum pump | 2CFM dual stage |
| Vacuum pump oil quantity | 250ml |
| Compressor capacity | 0.87cu in/14cc |
| Dryer filter | 75kg of recovered R134a |
| Non-condensable gas purge | Automatic via solenoid valve |
| HP and LP taps | Automatic |
| Display | LCD monochrome FSTN 240x64 dots |
| Keypad | Membrane |
| Software updating | USB type A or USB type B direct connect to PC |
| Printer (optional) | Thermal, 24 columns |
| All functions | Automatic and manual |
| Recycling mode | Single or multipass |
| Memory for customized cycles | 100 records |
| Flushing | With integrated solenoid valves |
| System pressure diagnostics | Manual and automatic |
| Dryer filter replacement alarm | Active |
| Vacuum pump oil replacement alarm | Active |
| Full/empty tank check alarm | Active |
| Full oil container check alarm | Visual |
| Empty oil container alarm | Visual |
| Dimension HxWxD | 119 x 74 x 74 cm |
| Dry weight | 98kg |
| Power supply frequency | 60Hz |
| Voltage | 120VAC, 1 phase |
| Total max load | 7.5A |
| Overcurrent protection | 12A (circuit breaker) |
| Operating temperature | 50-122°F |
| Humidity | 10-90%RH (non condensing) |
| Storage temperature and humidity | -13 to 50°F 10-90%RH (non condensing) |
| Max operating altitude | 6562ft |
| Pollution degree | 2 |
| Water degree | 0 |
| Certifications | SAE J2788 UL1963 CAN/CSA STD C22.2 NO. 120-M91 |

5. Equipment installation

5.1 Unpacking ACX2120H



Warning – Risk of personal injury!
Incorrect handling could cause equipment to overturn.



► The manufacturer disclaims all responsibility for damage to objects and/or persons resulting from the equipment being wrongly removed from the pallet, or if the operation is performed by unsuitable personnel, with improper means/ protections and without complying with the existing laws on manual handling of loads and with the operations described in this manual.

1. Cut the straps and remove the carton (Fig. 9)

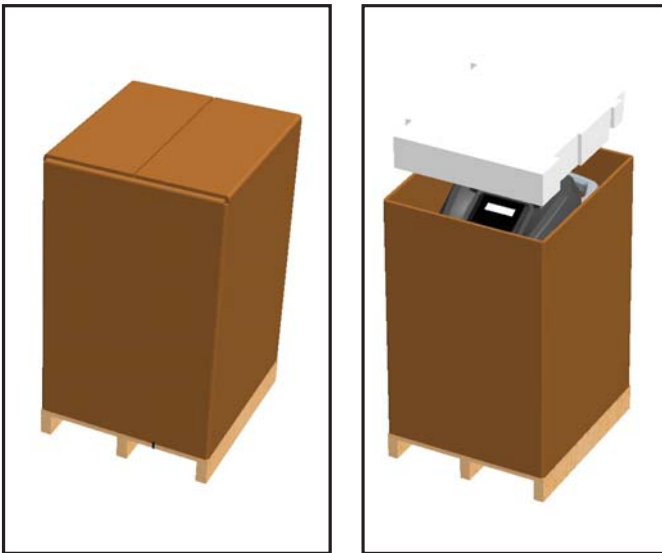

Fig. 9: Removing carton

2. Cut straps securing unit to pallet.
3. With 2 people, lift both front wheels by levering with the handle so unit is setting on the rear wheels (Fig. 10).



Fig. 10: Tilting unit backwards

4. Slowly lower the unit from pallet by means of the rear wheels (Fig. 11).



Fig. 11: Lowering unit from the pallet

5. Keep the pallet, carton, and scratch protection film for use in case of a need to return unit.

5.2 Load cell screw release

- ❗ The ACX2120H is shipped from the manufacturing facility with the load cell blocked to prevent damage during shipment.
1. On the underside of the unit (towards the front) there is a screw with a wingnut threaded into the base. Loosen the wingnut and unscrew bolt (Fig. 12).

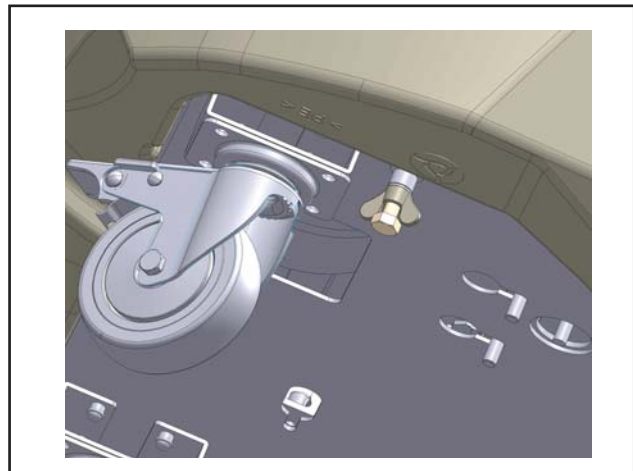

Fig. 12: Removing load cell retention bolt

6. Commissioning

- i** All the operations described in Section 5 and 6 must be performed prior to first A/C service.

6.1 Connections and positioning

- ⚠** The ACX2120H is designed for 110V, 50/60Hz. Follow the information on the ACX2120H rating plate.

1. Set the ACX2120H on a flat, vibration-proof surface.
2. Actuate the caster brake to stop the ACX2120H from rolling.
3. Connect the power supply cable to the power supply.
4. Switch on the main switch.

- ⚠** The unit must be positioned on a stable, horizontal surface to ensure correct operation. Unit must be in an area with proper ventilation and at least 10cm from any potential obstacle to its internal ventilation.

- ⚠** Keep unit out of rain and excessive humidity as moisture could cause irreparable damage.

- ⚠** Prevent exposure to direct sunlight and excessive dust.

- ⚠** Unit must be properly grounded with the power plug ground pin. Failure to ground unit can cause damage and constitutes a risk of fatal injury or shock to the operator.

- i** Do not unplug any internal electrical connections and only have internal components opened and repaired by trained customer service personnel.

- i** Contact customer service in the event of any transportation damage (e.g. oil leakage).

- i** Leave quick couplings closed when unit is not in use and at end of vehicle service operations.

6.2 First start-up verification

Warning - Risk of frostbite from escaping refrigerant



Refrigerant causes frostbite on the skin

- ▶ Check the service hoses for damage.
- ▶ Firmly connect the service quick-release couplings to the service hoses.
- ▶ Wear protective goggles.
- ▶ Wear protective gloves.

Execute the following actions in sequential order by following the procedure as shown on the display:

- Gas weight check (vacuums entire refrigerant circuit to ensure no contaminants are in system prior to filling)
- First internal cylinder fill

- i** It is possible to interrupt the initial check and print a report in which the status of the check is reported (if printer option was purchased).

- i** Equipment cannot operate in automatic mode until all the steps of initial check are completed.

1. Set the internal cylinder fill to desired quantity (min. 3kg).
2. Follow on-screen instructions.
3. Make sure hoses are disconnected from any external source at this time.
4. Start the procedure that initially creates vacuum in the internal refrigerant circuit (approximately 15 minute process).
5. Once message is displayed, the unit can be connected to the external cylinder and the valves opened.
6. Just before the targeted refrigerant amount is reached, unit will pause and prompt user to close external refrigerant tank connection.
7. Once this is done, the unit will continue to recover the refrigerant from the hoses and end once this is completed. The total amount recovered will then be displayed.

- i** Check the type of source tank, two types are available:

- **Refrigerant cylinder with plunger (typically 2 valves):**
Connect to the the liquid valve and keep tank in the upright position to transfer refrigerant.
- **Refrigerant cylinder without plunger (single valve):**
Connect to the available valve and invert tank to transfer refrigerant.



Fig. 13: Virgin refrigerant cylinder tank types

- i** The LP (blue) gauge indicates the pressure inside the external cylinder.

7. Setup

7.1 ACX2120H

- i** From the **SETUP** menu, it is possible to enable/disable and set certain parameters prior to performing A/C system service. To access **SETUP** from the main menu, press **↓↑** to highlight **SETUP** and then press **↵**.

| Parameter | Description |
|--------------------|---|
| EcoLOCK | Enable/disable EcoLOCK functionality |
| Recharge mode | Select Quick mode or Zero tolerance recharge method |
| Pressure check | Enable/disable the pressure check |
| Multipass | Enable/disable the Multipass function |
| Report saving mode | Adjust what reports are saved during A/C service mode |
| Unit of measure | Modify the unit of measure for pressure and weight |
| Clock adjustment | Modify the date and time |
| Language | Modify the language displayed on the unit LCD display |
| Startup screen | Select if upon power-up the unit displays the database page or main menu screen |
| Default setup | Restore unit default settings |

- i** If while adjusting settings user does not want to apply any change made, just press **ESC** from the parameter screen to discard the change made to that specific area.

7.1.1 Ecolock (optional)

- From the **SETUP** menu, press **↓↑** until **Ecolock** is highlighted and press **↵**.
- Adjust whether the EcoLOCK function is enabled or disabled by pressing **↔**.
- Press **↓** to highlight **SAVE**, then press **↵** to save selection.

7.1.2 Recharge mode

- i** For a more detailed description of the 2 charge modes, see Section 8.3.
- From the **SETUP** menu, press **↓↑** until **RECHARGE MODE** is highlighted and press **↵**.
 - Adjust whether the Recharge mode is in **Quick mode** or **Zero tolerance** by pressing **↔**. (If Zero Tolerance mode is selected, press **↓** to highlight the pressure and use **↔** to adjust the value.)
 - Press **↓** to highlight **SAVE**, then press **↵** to save selection.

7.1.3 Pressure check

- From the **SETUP** menu, press **↓↑** until **PRESSURE CHECK** is highlighted and press **↵**.
- Adjust whether the Pressure check function is enabled or disabled by pressing **↔**.
- Press **↓** to highlight **SAVE**, then press **↵** to save selection.

7.1.4 Multipass

- i** **Multipass** is a function user can enable that will run when unit is powered up and in an idle state. This function circulates the refrigerant from the internal cylinder through the filters to ensure optimal purity.

- From the **SETUP** menu, press **↓↑** until **MULTIPASS** is highlighted and press **↵**.
- Adjust whether the Multipass function is enabled or disabled.
- Press **↓** to highlight **SAVE**, then press **↵** to save selection.

7.1.5 Report saving mode

- From the **SETUP** menu, press **↓↑** until **REPORT SAVING MODE** is highlighted and press **↵**.
- Adjust whether all cycle reports, automatic cycles only or no reports are saved by pressing **↔**.
- Press **↓** to highlight **SAVE**, then press **↵** to save selection.

7.1.6 Unit of measure

- From the **SETUP** menu, press **↓↑** until **UNIT OF MEASURE** is highlighted and press **↵**.
- Use **↓↑** to select if Pressure or Gas units are to be adjusted, then press **↵**.
- Adjust the units by pressing **↔**.
- Press **↓** to highlight **SAVE**, then press **↵** to save selection.
- If other units are to be adjusted, press **↓↑** to select other parameter or press **↓** to highlight **SAVE**, then press **↵** to save any changes.

7.1.7 Clock adjustment

1. From the **SETUP** menu, press **↓↑** until **CLOCK ADJUSTMENT** is highlighted and press **↵**.
2. Highlight value that needs to be adjusted by pressing **↵**.
3. Adjust value by pressing **←→**.
4. Press **↵** until **SAVE** is highlighted, then press **↵** to store entries and return to Setup menu.

i Date is displayed as follows: DD/MM/YYYY.

7.1.8 Setting language

1. From the **SETUP** menu, press **↓↑** until **LANGUAGE** is highlighted and press **↵**.
2. Adjust the language by pressing **←→**.
3. Press **↓** to highlight **SAVE**, then press **↵** to save selection.
4. Unit will restart upon saving the language selection.

⚠ If a language is selected that is not understood, simply switch unit off, depress enter key (**↵**), and turn unit back on (keeping **↵** depressed). This will automatically load the language selection screen.

7.1.9 Startup screen

1. From the **SETUP** menu, press **↓↑** until **STARTUP SCREEN** is highlighted and press **↵**.
2. Adjust whether the unit startup screen is the main menu or if unit goes directly to the database using **←→**.
3. Press **↓** to highlight **SAVE**, then press **↵** to save selection.

7.1.10 Default setup

1. From the **SETUP** menu, press **↓↑** until **DEFAULT SETUP** is highlighted and press **↵**.
2. Press **↵** to reset all settings to the factory settings.

8. A/C service preparation

8.1 Preliminary preparation



Warning - risk of burns from hot engine components

Contact with hot engine components will cause severe burns.



- ▶ Allow the engine to cool down.
- ▶ Wear protective goggles.
- ▶ Wear protective gloves.



Warning - risk of frostbite from escaping refrigerant

Refrigerant causes frostbite on the skin.



- ▶ Check the service hoses for damage.
- ▶ Firmly connect the service quick-release couplings to the service hoses.
- ▶ Wear protective goggles.
- ▶ Wear protective gloves.

Perform the following preparatory work prior to vehicle A/C service:

- ⚠ Service hoses must be constructed of the proper materials and have the lengths as supplied with the unit. Hoses must have shutoff devices (quick-release couplers) at the connection point to the A/C to minimize the introduction of air into the ACX2120H and to minimize the amount of refrigerant released while disconnecting the hoses.
- ⚠ Inspect hoses for signs of damage prior to performing A/C service. Use of damaged hoses will result in the loss of refrigerant and the possibility of refrigerant contamination.
- ℹ Follow the vehicle manufacturer's recommendations for A/C service on vehicles with a low-pressure connection only.
 1. Set the ACX2120H on a flat, vibration-proof surface.
 2. Actuate the caster brake to stop the unit from rolling.
 3. Connect the power supply cable to the power supply.
 4. Switch on the main switch.
- ⚠ Follow the manufacturer's instructions for the corresponding vehicle before performing A/C service.
- ⚠ A/C service operations (especially recovery) should be performed after the vehicle has been run for a period of time to allow engine heat to raise system pressure. This allows for the maximum refrigerant recovery amount to occur. If system is excessively hot, the recharge phase could be adversely effected.
- ⚠ The ACX2120H is only to be operated with R134a refrigerant. Check which refrigerant is used for the vehicle before performing A/C service.
- ⚠ The ACX2120H cannot be used for air conditioning systems repaired using a chemical sealant. Non compliance will void the warranty.

- ⚠ Never attempt to close the valves of the internal refrigerant bottle while the ACX2120H is in operation.
- ⚠ Only new lubricant, as specified by the system manufacturer, shall be installed in the MAC system. Lubricant removed from the system and/or equipment shall be disposed of in accordance with the applicable federal, state, and local procedures and regulations.
- ℹ The service parameters (recharge quantity) can be found in the owner's manual or the vehicle repair manual.

8.2 Non-condensable gas discharge

- ℹ If the ACX2120H detects non-condensable gases in the internal cylinder, the unit will prompt technician to allow unit to run an air purge. This prompt will occur every time unit is powered on (if unit has been powered off for at least 1 hour).
- ℹ The process will perform automatically upon the start of a charge procedure if non-condensibles are detected.
- ℹ Air purge is a necessary process to ensure ideal working parameters for the ACX2120H. Presence of non-condensable gases will increase tank pressure and reduce efficiency of recharge cycles.

8.3 Charge modes

- ℹ The ACX2120H has 2 different refrigerant charge methods. If charge does not complete using Quick mode, the Zero tolerance method automatically commences.

8.3.1 Quick mode

- ℹ In Quick mode, the ACX2120H injects refrigerant through the HP port. The refrigerant remains in the hoses at the end of the cycle and is then recovered during a hose clearing process.

8.3.2 Zero tolerance mode

- ⚠ While the Zero tolerance mode is slightly longer in time, it provides a more accurate recharge and guarantees a successful charge.
- ℹ In Zero tolerance mode, the ACX2120H will by default charge through the HP (red) hose, then refrigerant that remains in the hoses is pulled into the vehicle's A/C system through the LP (blue) hose.
- ℹ In the instance where only a LP coupling is available for A/C service, the ACX2120H will charge the system with 50% of the total charge amount with the vehicle A/C compressor off. The unit then waits 10 minutes to allow the liquid refrigerant to evaporate to prevent damage to the compressor. The vehicle must be started and the A/C system turned on. The ACX2120H will continue to charge refrigerant whenever the LP hose pressure is less than 3 bar.

9. A/C system service

9.1 Automatic cycles

i Access to automatic cycles is available through the main menu by selecting **“AUTOMATIC CYCLES”**.

- To begin Automatic cycle setup, user must first select whether they would like to load the parameters used during the last A/C service or select My database to load custom parameters previously saved by the technician.

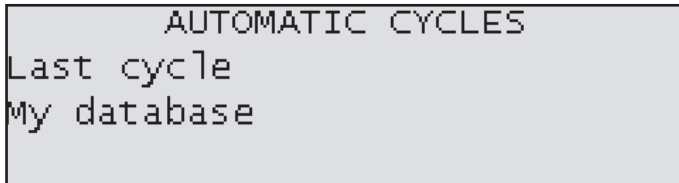

Fig. 14: Automatic cycle selection

- After the selection is made, a screen will appear showing the data for the process (Fig. 15).

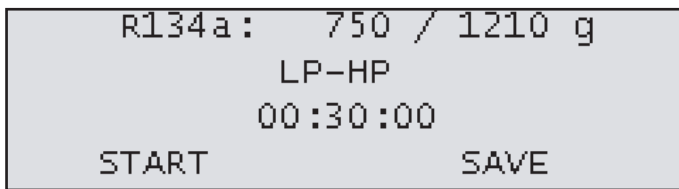

Fig. 15: Parameter adjustment

i The amount of refrigerant to be charged into the system and the amount of refrigerant available in the internal cylinder are listed in the top row of the screen. To adjust the charge amount, highlight the value and press $\leftarrow \rightarrow$ to adjust the value higher or lower. Press \leftarrow to save selection and move to next parameter.

i The second row displays the hose selection for the service. To adjust the hose selection, highlight the current value and press $\leftarrow \rightarrow$ to adjust. Press \leftarrow to save selection and move to next parameter. The following options are available:

- HP only
- LP only
- HP and LP
- HP(LP) - Injection through HP hose on the system low pressure side (Specific for some Renault models).

i Third row of information displays the vacuum time. To adjust the vacuum time, highlight the value and press \leftarrow . Adjust vacuum time by using $\leftarrow \rightarrow$ to change value then press \leftarrow . Adjust vacuum test time using the same method. Press \leftarrow to save selection and move to next parameter.

- After the parameters are adjusted, press \downarrow to select and confirm **START** to begin the Automatic cycle. (Or press \downarrow a second time to select and confirm **SAVE** to save the cycle information to My Database.)

- A screen will then appear to adjust the vehicle's compressor type (Fig. 16). Use $\leftarrow \rightarrow$ to change between **ELECTRIC** and **MECHANICAL** compressor type, press \downarrow to select **CONTINUE**, then press \leftarrow .

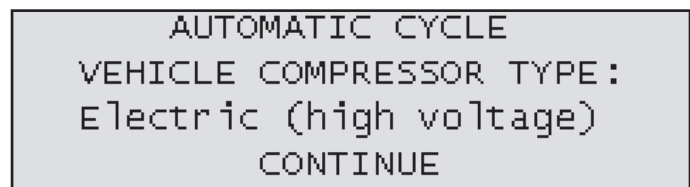

Fig. 16: Compressor type selection

- If the selected type is Electric (high voltage), a special flushing procedure will be executed to clear any potential oil residue in hoses from previous services. The screen in Fig. 17 will appear and the hoses should be connected as illustrated in Fig. 18.

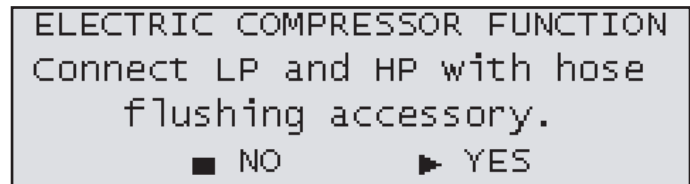

Fig. 17: Electric compressor function



Fig. 18: Flush adaptor connection

- After the connection is made, confirm YES (by pressing \leftarrow) to proceed and follow instructions displayed on screen.

9.2 Manual cycles

- i** Access to manual cycles is available through the main menu by using $\downarrow\uparrow$ to select "

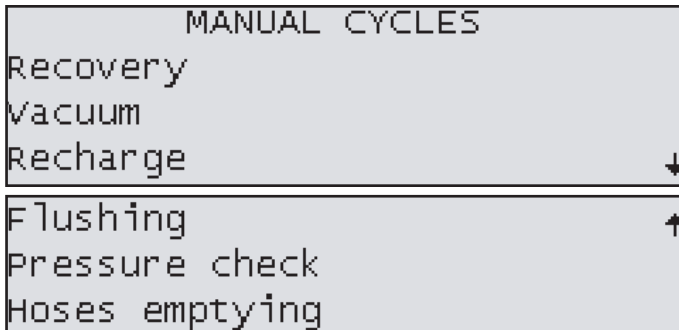

Fig. 19: Manual mode screen options

9.2.1 Recovery process

1. In the manual cycle menu, use $\downarrow\uparrow$ to select Recovery and press \leftarrow .
2. Follow on screen instructions to begin recovery process.

- i** If no pressure is detected in the system, this function will not start. Technician should ensure couplers are open. If the system is empty, operator must exit and select a vacuum process.

- ⚠** There is potential for unit to display an error during this service for high internal pressure. This can occur due to high operating temperatures or hot refrigerant gasses entering the ACX2120H.

9.2.2 Vacuum process

1. In the manual cycle menu use $\downarrow\uparrow$ to select Vacuum and press \leftarrow .
2. The unit will display a screen for technician to enter the length of vacuum time and vacuum test time. (press \downarrow to display Vacuum test time screen).
3. Connect HP/LP coupler(s) to the vehicle A/C system, open the couplers and select START.

- i** Be sure recovery has been performed prior to running a Vacuum cycle.

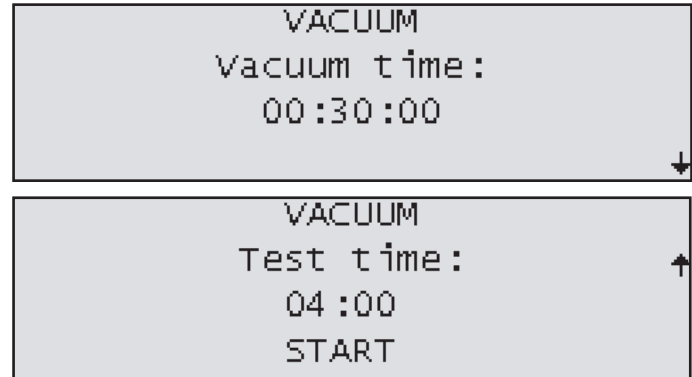

Fig. 20: Vacuum setup screens

9.2.3 Recharge

1. In the manual cycle menu use **↓↑** to select **RECHARGE** and press **↵**.
2. Adjust the value on the screen to match what the vehicle's A/C system requires by pressing **←→**. Note: If the value entered is higher than what is available in the internal cylinder, the procedure will not begin.
3. Set whether service is to be performed on:
 - HP only
 - LP only
 - HP & LP
 - HP(LP) - Injection through HP hose on the system low pressure side (Specific for some Renault models).
4. Connect couplers to the vehicle fittings and follow on-screen instructions.

9.2.4 Flushing (with optional accessories)

- i** After replacing components or parts of the A/C system, it is advisable to carry out a system flush procedure.
 - i** The system flush process charges liquid refrigerant through the connected components and filters impurities through an additional filter.
1. Install flushing kit as described in the instructions included with kit.
 2. Follow on-screen instructions.

9.2.5 Pressure check

- i** This process is used to check the pressure inside the vehicle's A/C system using the ACX2120H.
1. Connect HP & LP couplers to the vehicle A/C system.
 2. Follow on-screen instructions - start vehicle and turn on the A/C system.
 3. Set temperature at coldest setting.
 4. Set fan speed at maximum level and close all vents except the central one and set air distribution to that vent.
 5. Keep engine at a high idle speed (approx. 2000RPM) for at least 2 minutes.
 6. Check pressure values in 3-5 minutes.
 7. Once these steps are complete, select Pressure Check function.
 8. At the end, check that both values on the HP and LP gauges fall between the values shown on the display.
- ⚠** Pressure values change considerably when ambient temperature changes. Keep this in mind when checking pressure values.

9.2.6 Hose emptying

1. To clear pressure from inside unit hoses, in the manual cycle menu use **↓↑** to select hose emptying and press **↵**.
2. Allow procedure to run to completion.

10. Maintenance

- i** Please contact an authorized technical service center for purchasing factory replacement parts.

10.1 Maintenance interval

| Description | Period |
|--|-------------------------------------|
| Calibration of scales | 1x per year to ensure accuracy |
| Vacuum pump oil replacement and system leak test | After 1000 hours of service |
| Combo filter replacement and system leak test | After 75kg of refrigerant processed |
| System leak test | As required |

- ⚠** Make sure ACX2120H is disconnected from power before removing plastic housing.
- ⚠** Never perform any maintenance work which is not expressly recommended in this Section.
- ⚠** Contact customer service if components have to be replaced other than in the course of maintenance work.
- i** To access MAINTENANCE from the main menu, press **↓↑** to highlight MAINTENANCE and then press **↵**.

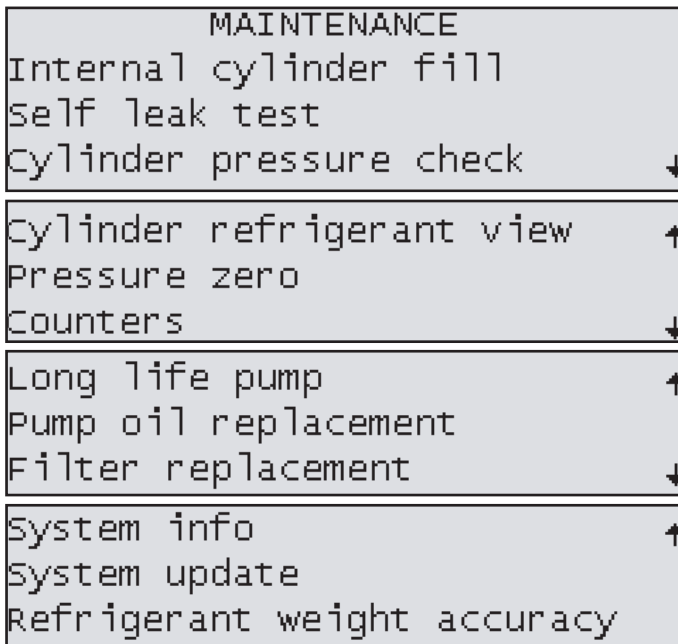

Fig. 21: Maintenance screens

10.2 Filling internal refrigerant cylinder



Warning - Risk of frostbite from escaping refrigerant

Refrigerant causes severe frostbite on the skin.



- ▶ Check the service hoses for damage.
- ▶ Firmly connect the service quick-release couplings to the service hoses.
- ▶ Wear protective goggles.
- ▶ Wear protective gloves.

- i** Before the ACX2120H can be used, the internal refrigerant cylinder must be filled with liquid refrigerant. Use only R134a refrigerant.
- i** The refrigerant can be obtained from your gas supplier. It can be stored normally and transported in bottles with connection fittings.
- i** To ensure a reliable procedure, it is advisable to use the optimum quantity of refrigerant. The optimum quantity of refrigerant for the ACX2120H is 4kg – 10.0kg.
- i** An inadequate quantity may make efficient filling of the vehicle air conditioning system impossible. Also, if there is an insufficient quantity, the ACX2120H may not be able to operate efficiently. In the event of an excessive quantity, there may not be sufficient space for the refrigerant recovered from the vehicle air conditioning system.

- ⚠** Do not open coupler until unit prompts technician to open.

1. From the **MAINTENANCE** menu, press **↓↑** until **INTERNAL CYLINDER FILL** is highlighted and press **↵**.
2. To adjust the charge amount, highlight the value and press **←→** to adjust the value higher or lower.
3. Press **↵** to accept value and press **↵** again to begin process.
4. Follow the menu prompting.

- i** The current pressure inside the external refrigerant bottle is indicated on the low-pressure gauge.

- ⚠** Do not interrupt the automatic filling process prior to automatic termination by the ACX2120H.

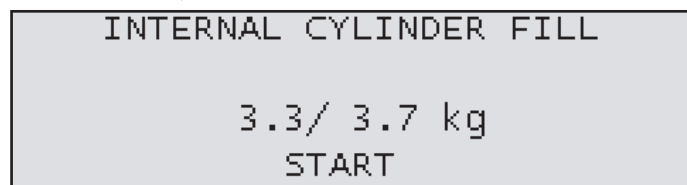

Fig. 22: Internal cylinder fill setup screen

10.3 Self leak test

- i** This test is designed to check the internal ACX2120H circuit for any leaks.

To perform Self leak test:

- From the **MAINTENANCE** menu, press **↓↑** until **SELF LEAK TEST** is highlighted and press **↵**.
- Allow unit to perform test to completion.

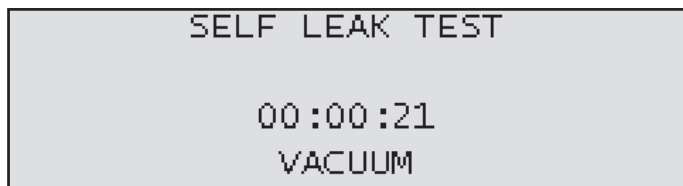

Fig. 23: Self leak test screen

- i** If a test fails, check charge hoses and quick couplers for leak first. If repair is possible, fix the leak and repeat test.

10.4 Cylinder pressure check

- From the **MAINTENANCE** menu, press **↓↑** until **CYLINDER PRESSURE CHECK** is highlighted and press **↵**.
- Screen will display message shown in Fig. 24.

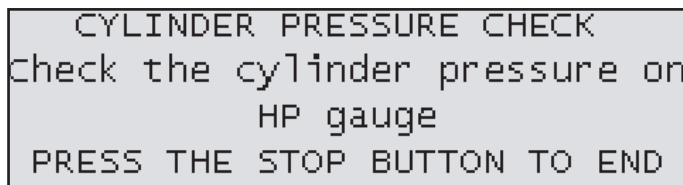

Fig. 24: Cylinder pressure check screen

- Press stop once HP (red) gauge displays pressure inside tank.

10.5 Cylinder refrigerant view

- From the **MAINTENANCE** menu, press **↓↑** until **CYLINDER REFRIGERANT VIEW** is highlighted and press **↵**.
- Screen will display the Total refrigerant weight and the Available refrigerant weight.

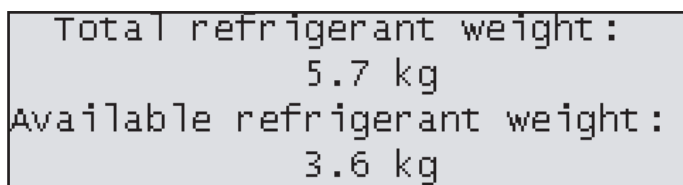

Fig. 25: Refrigerant weight screen

- i** Available refrigerant weight is 2kg less than total contents of cylinder. 2kg is the minimum quantity that should be left in an operating ACX2120H.

10.6 Pressure zero

- i** This function allows technician to determine and store the atmospheric pressure value.

- From the **MAINTENANCE** menu, press **↓↑** until **PRESSURE ZERO** is highlighted and press **↵**.

- ⚠** This procedure should be performed every time the ACX2120H is moved from one location to another that has a different altitude.

10.7 Counters

- i** These screens will display the vacuum pump and compressor hours of life and the remaining time before vacuum pump oil and the filter dryer need replacement.

- From the **MAINTENANCE** menu, press **↓↑** until **COUNTERS** is highlighted and press **↵**.
- Press **↓↑** to display all counters.

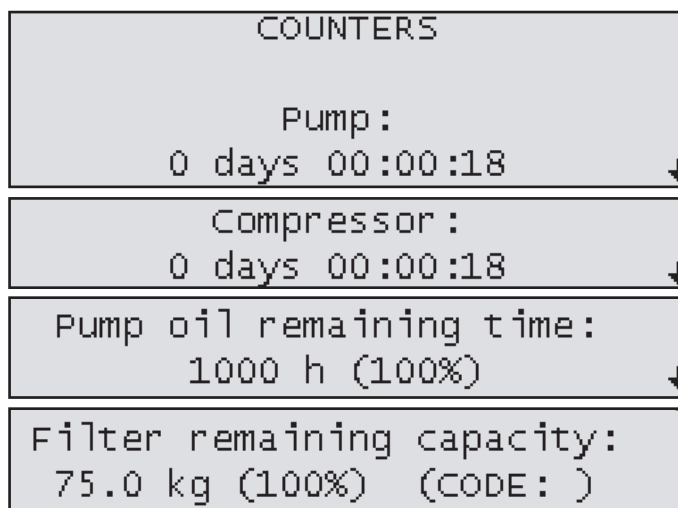

Fig. 26: Counters

10.8 Long life pump test

- i** The Long Life Pump function equipped on the ACX2120H enables the unit to optimize the vacuum pump oil use and avoid the need to replace after every 60 hours of operation.
1. After the first 60 hours of vacuum pump operation, check the vacuum pump oil level and top-off if necessary.
 2. From the **MAINTENANCE** menu, press **↓↑** until **LONG LIFE PUMP TEST** is highlighted and press **←**.
 3. The process will run for approximately 1 hour.
- i** During this process, the vacuum pump oil is automatically purified from the gaseous residues absorbed by the oil during the vacuuming of vehicle A/C systems.
4. At end of procedure, vacuum pump performance check is executed and the result is displayed on the display.
- i** If the result of the Long Life Pump test is negative, the oil must be changed.
 - i** If the results pass, the pump oil remaining time will change to 1000 hours. After 1000 hours of runtime, the oil must be changed.

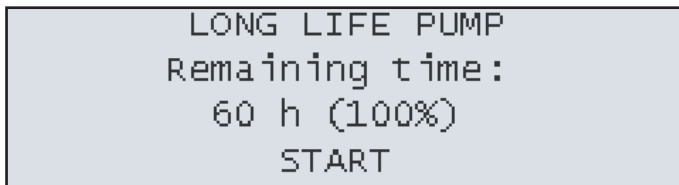

Fig. 27: Long life pump screen

10.9 Vacuum pump oil change

- i** After 60 hours of runtime (or 1000 hours if the Long Life Pump test is completed successfully), the vacuum pump oil must be replaced.

1. Disconnect ACX2120H from power.
2. Unlock front latch and carefully lift cover.

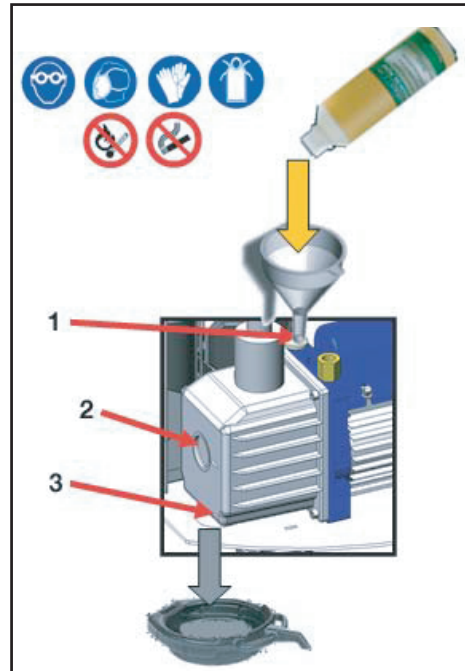

Fig. 28: Changing vacuum pump oil

- 1 Oil filling plug
- 2 Oil inspection window
- 3 Lower drain plug

3. Place a bowl under the vacuum pump oil drain hole. Remove the upper filling plug and the lower drain plug to allow the oil to drain from unit.
4. Once the pump has been emptied, reinstall the lower drain plug.
5. Fill the pump with new oil through the upper fill port using a funnel if needed. Fill until the oil appears halfway up the oil level inspection window.
6. Once the pump has been filled, reinstall the upper fill plug.
7. Carefully close front cover and secure latch.
8. Connect to power and turn on.
9. From the **MAINTENANCE** menu, press **↓↑** until **PUMP OIL REPLACEMENT** is highlighted and press **←**. Press the **RESET** key to set the counter.

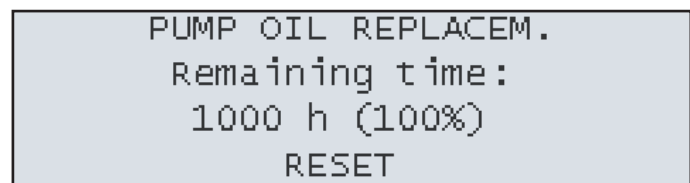

Fig. 29: Reset vacuum pump oil life

- i** The level and clearness of the vacuum pump oil can be checked by removing the rubber plug located on the front-left side of the unit.

10.10 Replace filter dryer



Warning - Risk of frostbite from escaping refrigerant

Refrigerant causes severe frostbite on the skin.



- ▶ Check the service hoses for damage.
- ▶ Firmly connect the service quick-release couplings to the service hoses.



- ▶ Wear protective goggles.
- ▶ Wear protective gloves.

i Unit operation is disabled at the end of the filter service life. Each filter is marked with a unique code. This code must be entered when replacing the filter. It is not possible to operate the ACX2120H if the same code is re-used. It is advisable to keep a supply of filters in stock to avoid downtimes due to the unit being disabled.

i The ACX2120H is disabled once 75kg of R134a refrigerant has passed through the filter. A new filter must be installed and its unique code entered in the ACX2120H before vehicle A/C service can be performed.

1. To begin the filter replacement process, from the **MAINTENANCE** menu, press **↓↑** until **FILTER REPLACEMENT** is highlighted and press **↵**.
2. Insert the new filter code using the keypad.

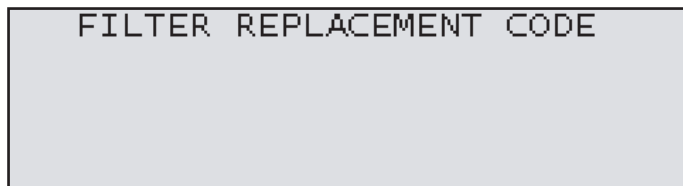

Fig. 30: Filter code entry

3. Disconnect the HP and LP couplers and hoses and allow the hose drain process to run to completion.
4. Disconnect ACX2120H from power supply.
5. Turn front locking latch using a flathead screwdriver and carefully open the front housing.
6. Unscrew the 2 connection nuts from top and bottom of the filter using a 17mm open-ended wrench to prevent the filter from spinning and a 24mm open-ended wrench to loosen the nuts.
7. Remove the straps that hold filter in place.
8. Install new filter paying attention to the position of the gaskets and ensure arrow faces downward.

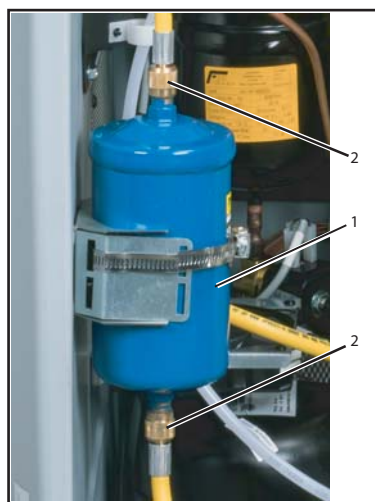

Fig. 31: Replacing filter

- 1 Filter dryer
- 2 Connection nuts

9. Tighten the 2 connection nuts to the filter.
10. Close front housing and secure latch.
11. Connect unit to power and turn on.
12. Allow unit to perform the automatic leak test requested by the software when unit loads.

⚠ Take care not to damage any hoses or electrical connections when changing the filter.

⚠ Never re-use an old filter.

10.11 Multipass

i Run this procedure to circulate refrigerant within the ACX2120H. This allows the unit to further purify the refrigerant and remove any dirt/other impurities.

10.12 System info

i In the Info page, the software version and serial number can be displayed.

1. From the **MAINTENANCE** menu, press **↓↑** until **SYSTEM INFO** is highlighted and press **↵**.

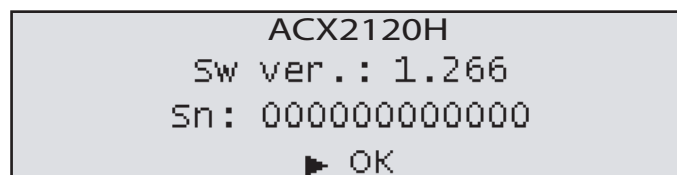

Fig. 32: System information screen

10.13 Software update

- i** The firmware (software can be updated by way of a USB stick.
 1. Insert USB stick in USB port (Fig. B Pos. 2).
 2. Power on ACX2120H.
 3. From the **MAINTENANCE** menu, press **↓↑** until **SOFTWARE UPDATE** is highlighted and press **↵**.
 4. A message will appear that the unit is loading an update.
 5. The unit may load an updated language file and configuration file while updating.
 6. Once unit is updated, the software version string on the introduction screen during power up will change.

10.14 Refrigerant weight accuracy test

- i** An automatic procedure is built in to the system that allows the technician to check the accuracy of the refrigerant weight scale.
 - ⚠** Before removing the front panel of the ACX2120H, turn unit off and disconnect power cord.
 1. Turn front locking nut using a flathead screwdriver and carefully lift the front cover.
 2. Unscrew the bolt and wingnut that hold the reference weight to the base panel of the equipment.



Fig. 33: Reference weight location

- 1 Reference weight
3. Connect the power cord to power supply and switch on unit.
4. From the **MAINTENANCE** menu, press **↓↑** until **REFRIG - Erant weight accuracy check** is highlighted and press **↵**.
5. Press **YES** (**→**) to continue when the screen in Fig. 34 appears.

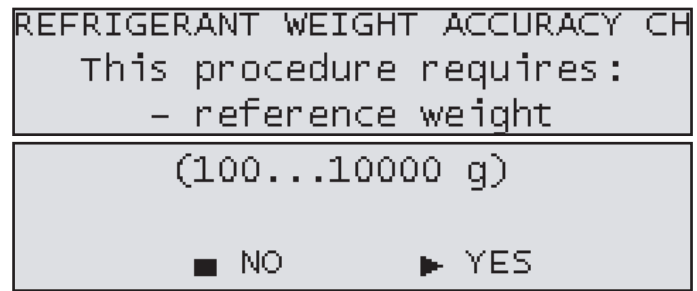

Fig. 34: Refrigerant weight check screens

6. Follow the instructions on the screen and when the screen in Fig. 35 is displayed, place the reference weight below the tank over the two screws of the load cell and press **YES** (**→**).

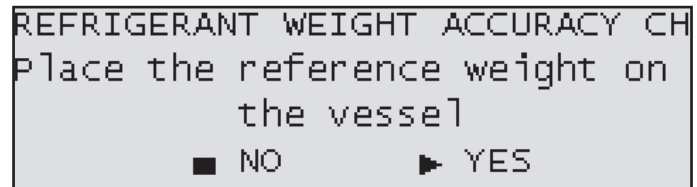

Fig. 35: Place weight screen

7. Type the weight of the reference weight in the screen below and press **↵**.

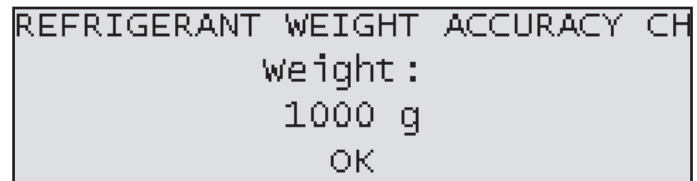

Fig. 36: Weight entry screen

- i** The mass of the reference weight should be identified on a side of the weight.
 8. Allow unit to perform the check of the load cell calibration.
 9. After the check is complete, a pass or fail result will be displayed.
 10. Switch off unit and disconnect power cord.
 11. Return reference weight to its position on the base panel of the ACX2120H and reinstall front plastic.
 12. Carefully close the front cover and secure the latch using a flathead screwdriver.
- ⚠** In the case of a failure during the Refrigerant weight accuracy check, perform the test a second time for verification. If the resulting test is a second failure, a calibration of the internal refrigerant weight scale should be performed.

10.15 Printer maintenance (optional)

1. Open the lid of the printer as shown in Fig. 37.

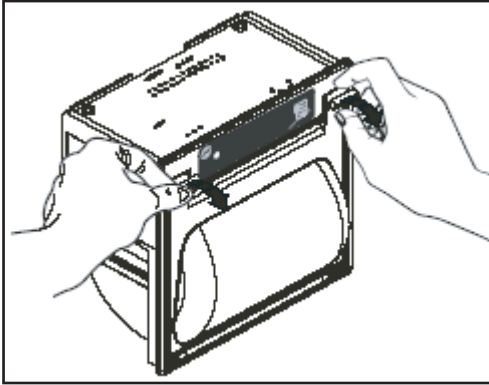

Fig. 37: Opening printer

2. Position the roll of paper inside the housing in the rotation direction indicated in Fig. 38.

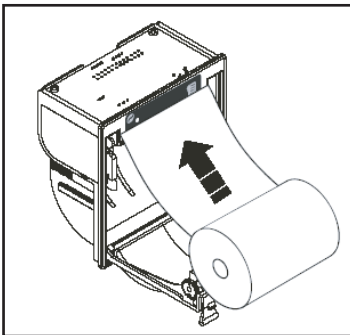

Fig. 38: Installing new paper roll

3. Pull the paper out of the housing as shown in Fig. 39 and close the lid.

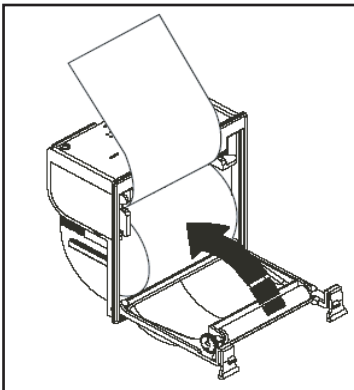

Fig. 39: Completing installation

4. The printer is ready for printing.

10.16 Periodic checks

- i The ACX2120H service station must be checked over regularly as set by local legislation.

- ⚠ The following checks should be performed to ensure safe and reliable operation:
 - Make sure no corrosion or leakage is present in the internal cylinder and other metallic parts of the equipment (under normal conditions the internal cylinder life is at least 20 years).
 - If automatic safety valve trips, contact technical support to have unit inspected, resolve any issues and replace valve if necessary.
 - If the safety pressure switch trips, check the connection of the cables and correct connection to the PCB. Contact technical support for additional assistance.
 - Check that external charging hoses - both red (HP) and blue (LP) - are in good order and undamaged. In the case of damaged hoses, discontinue use of ACX2120H until replacement hoses are procured.
 - Verify that vacuum pump oil and filter dryer have been replaced according to schedule for proper functioning equipment.

11. Spare parts

| Description | Order number |
|---|--------------|
| Combo filter | 026 80776 00 |
| Vacuum pump oil | 011 80070 00 |
| Paper for printer (5 rolls) | 360 83110 00 |
| Service hose (HP) | 028 80532 00 |
| Service hose (LP) | 028 80533 00 |
| Quick-release coupling (HP) | 023 80095 00 |
| Quick-release coupling (LP) | 023 80096 00 |
| Used oil bottle | 026 80783 00 |
| Safety goggles (accessory item) | 360 82956 00 |
| Protective gloves (accessory item) | 360 82957 00 |
| Dust cover (accessory item) | 026 80697 00 |
| Adapter LP (external bottle), US ACME 1/2 | 023 80147 00 |

i Additional spare/replacement parts are available through the service centers authorized by MAHLE or by its reseller. Contact technical support for replacement parts not listed above.

12. Disposal

12.1 A/C Service unit disposal

At the end of its service life, this equipment must be disposed of as follows:

- Contact the service center to have the refrigerant in the unit recovered and recycled.
- Consign the unit to an authorized collection center according to local legislation.

12.2 Recycled material disposal

- Return the refrigerant recovered from the unit to the refrigerant supplier for proper disposal or recycling.
- Lubricants extracted from the vehicle's A/C system must be returned to an official oil collection center.

12.3 Packaging disposal

⚠ Electronic and electrical A/C service equipment must never be disposed of with domestic waste, but recycled appropriately.

- The packaging must be disposed of in conformity with local legislation.
- This contributes to protecting the environment.

13. Troubleshooting

i Please contact technical service if any of the actions suggested in this section cannot be implemented.

i Notice/Warning codes are coded **Wxxx** on the title of the window.

i Alarm codes are coded **Axxx** on the title of the window - alarms terminate procedure and prevent its resumption.

13.1 ACX2120H

| Error code | Messages | When it occurs | Possible solutions | Action |
|------------|---|--|---|--|
| W008 | REPLACE VACUUM PUMP OIL | - When required after Pump Monitoring system procedure | - Pump oil contaminated | - Replace pump oil |
| W009 | REPLACE DRYER FILTER | - Every year since installation | - Filter capacity is finished | - Replace dryer filter |
| W025 | REFRIGERANT QUANTITY TOO HIGH | - During the programming of the inner tank charge amount | - Amount required greater than that available in internal tank | - Decrease the set quantity. |
| W026 | RECHARGE CYLINDER EMPTY OR DISCONNECTED | - During the tank filling phase | - Recharging tank empty - Hoses/couplings are clogged/closed | - Check tank, hoses, taps. |
| W029 | CYLINDER NEAR FULL | - During the refrigerant recovery or hoses emptying phase. | - Tank close to maximum capacity | - Decrease quantity of gas by filling (injecting) an external suitable tank (with safety valve) |
| W032 | NO PRESSURE - VEHICLE WITHOUT REFRIGERANT OR DISCONNECTED | - During the refrigerant recovery phase | - Hoses not connected - Couplers not opened | - Check connections and leaks in A/C system |
| W044 | CYLINDER EMPTY | - During flushing or Tank refrigerant internal recycling phase | - Gas level is too low for the procedure to be completed | - Fill the internal tank with gas |
| W045 | LP VERY LOW, CHECK CIRCUIT BEFORE CONTINUING | - During flushing phase | - LP hose disconnected - Flushing couplings not properly connected - Leak in circuit being flushed. | - Reconnect LP and/or the fittings and eliminate any leaks. |
| W047 | POSSIBLE LEAKAGE | - During the refrigerant recovery phase | - Vehicle A/C system may have leaks | - Inspect vehicle A/C system and repair |
| A000 | EEPROM NOT WORKING | - Electronics fault | - EEPROM damaged | - Replace the logic electronic board |
| A001 | EEPROM DATA CORRUPT | - Electronics fault | - EEPROM damaged | - Replace the logic electronic board |
| A002 | PRESSURE SAFETY SWITCH ACTIVATED | - Pressure above 18 bar | - High pressure in the internal tank - Circuit between compressor and tank obstructed or closed | Verify: - If internal CYLINDER pressure level is over 18 bar, wait for pressure reduction, disconnect equipment from the mains, use safety protection - Open equipment and verify if the valve between compressor and internal CYLINDER are open |

| Error code | Messages | When it occurs | Possible solutions | Action |
|------------|--|---|--|--|
| A003 | ADC NOT WORKING | - Electronics fault | - ADC analog-digital converter damaged | - Replace the logic electronic board |
| A032 | CIRCUIT STILL UNDER PRESSURE | - During the vacuum, cylinder filling or leak test phase in vacuum | - The vehicle A/C system is pressurized | - Recover the refrigerant gas from the vehicle before starting another vacuum phase. |
| A033 | CIRCUIT LEAKAGE | - During the vacuum, cylinder filling or leak test phase, both under pressure and in vacuum | - Leakage in the circuit - Leakage in vehicle fittings | - Identify the leak position in the vehicle or connected system and have it repaired by trained and qualified staff according to local legislation. |
| A034 | VACUUM LEVEL TOO LOW | - During tracer injection and oil injection phase. The necessary vacuum level has not been reached. | - Vehicle A/C system is pressurized notwithstanding the vacuum phase - Possible presence of leakages in side A/C system - Vacuum phase time not sufficient or phase not executed (manual cycle). | - Repeat cycle, increase vacuum time - If leakages has been identified, identify the leak position in the vehicle or connected system and have it repaired by trained and qualified staff according to local legislation. |
| A035 | CYLINDER EMPTY | - During the gas injection and flushing phase | - Refrigerant gas is too low for the procedure to be completed - Refrigerant load cell out of calibration | - Fill the internal tank - Check calibration and calibrate if necessary |
| A036 | CYLINDER REFRIGERANT QUANTITY TOO LOW | - During the gas injection and flushing phase | - Gas amount in internal tank less than required - Refrigerant load cell out of calibration | - Fill the internal tank - Check calibration and calibrate if necessary |
| A037 | FURTHER REFRIGERANT INJECTION NOT POSSIBLE | - During gas injection phase | - Hoses not connected to vehicle A/C system - Couplers closed - Vacuum not sufficient - Presence of pressure in the circuit | - Caution: before proceeding, empty out the hoses - Repeat the recovery procedure and increase the vacuum phase duration |
| A038 | CIRCUIT LEAKAGE OR DISCONNECTED | - During flushing phase | - Leakages or obstructions in the circuit to be flushed | - Check the connection to the A/C system - Identify the leak in the circuit and have it repaired by trained and qualified staff according to local legislation. |
| A043 | CYLINDER FULL | - During the gas recovery and hoses emptying phase | - Internal tank full (maximum capacity level reached) | - Decrease quantity of gas by filling (injecting) an external suitable tank (with safety valve) |
| A047 | LP LEAKAGE | - At the end of the gas injection or, - In the Eco-Lock Lock patented technology quick couplers disconnection phase, or - During the vehicle fittings leak test | - Vehicle A/C system may have leaks at the LP port | - Empty the vehicle (follow the procedure guided by the displayed messages) - Replace LP port/schrader valve inside LP port |
| A048 | HP LEAKAGE | - At the end of the gas injection or, - In the Eco-Lock Lock patented technology quick couplers disconnection phase, or - During the vehicle fittings leak test | - Vehicle A/C system may have leaks at the HP port | - Empty the vehicle (follow the procedure guided by the displayed messages) - Replace HP port/valve inside HP port |
| A049 | LP AND/OR HP LEAKAGE | - At the end of the gas injection or, - In the Eco-Lock Lock patented technology quick couplers disconnection phase, or - During the vehicle fittings leak test | - Vehicle A/C system may have leaks at the HP and/or LP ports | - Empty the vehicle (follow the procedure guided by the displayed messages) - Replace HP and/or LP ports/valves inside ports |

15. Notes



MAHLE Aftermarket Inc., Service Solutions

10 Innovation Drive
York, PA 17402
USA

717-840-0678

www.servicesolutions.mahle.com

035 82681 00 (REV. A)
2019-03-04